

Design Features

- No moving parts to wear or fail.
- Electronics can be remotely mounted up to 30.5 m (100 ft).
- No fluid to sensor contact.
- No holes to clog.
- Aalborg's proprietary DSP algorithm accurately filters vortex frequency.
- High flow turndown ratio up to 10:1.
- Dual signal processing technology improves accuracy at low flows.
- Accuracy of 1% of rate.
- Noise cancellation technology.
- Extensive Diagnostics.
- Password protected data entry.
- Volumetric and mass flow information simultaneously displayed.
- Selectable engineering units.
- On board computer calculates density and mass flow.
- Two programmable totalizers.

Principles of Operation

Vortices are created when a fluid passes around a bluff body as shown in Figure 1. Vortices are alternately shed on each side of the body, 180 degrees out of phase to each other, resulting in an oscillating pressure gradient. As flow increases the frequency of vortices increases in proportion to the increased flow thereby creating a linear relationship.

General Description

Constructed of type 316 stainless steel, wafers may be installed in-line by customer provided or built-in flanges. Key pad or communication interface functionalities include measuring units, programmable flow alarm, two programmable totalizers, programmable flow rate pulse output, two programmable optically isolated outputs, battery backed real time clock (RTC), digital communication interface (RS-232 or RS-485), programmable diagnostic events log and register with date and time stamp, programmable process variable log with date stamp, calibration and flowing fluid parameters adjustment, extensive diagnostics.

Our exclusive dual signal processing technology independently measures each vortex on either side of the bluff body and filters out non-flow noise. This results in less noise and higher accuracy throughout the flow range. Aalborg's proprietary DSP algorithm accurately filters vortex frequency, improving the quality of flow measurements.

Local 2x16 LCD readout provides flow rate and total flow volume reading in selectable engineering units, diagnostic events indication and feature a password protected access to the process parameters to ensure against tampering or resetting.



Vortex In-line Flow Meter Shown with Wafer Mounting

Vortex In-line Flow Meter Shown with Flange Mounting

TABLE 52 - FUNCTIONAL SPECIFICATIONS

FLUID TYPES	Steam, Gas, Liquid.
MAXIMUM PRESSURE	69 bar (1000 psig) with wafer mount See Table 62 for flange mount.
FLUID TEMPERATURE	-20° to 232 °C. -4° to 450 °F.
LOW FLOW CUT-OFF	Adjustable: Set @ min. per Tables 57 to 61.
HIGH FLOW CUT-OFF	Adjustable: Set @ max. per Tables 57 to 61.
VOLTAGE	15 to 30 Vdc standard. 115 or 230 VAC optional.
FREQUENCY	50 /60 Hz.
OUTPUTS	Two user programmable analog 4-20 mA outputs (600 Ohms or less load), two sets of user-programmable optically isolated outputs, one user programmable optically isolated flow pulse output, RS-232 or RS-485 Digital Interface with Multi-Drop Capability of up to 255 units (RS-485 option).
LINEAR RANGE	Reynolds number of >10,000.

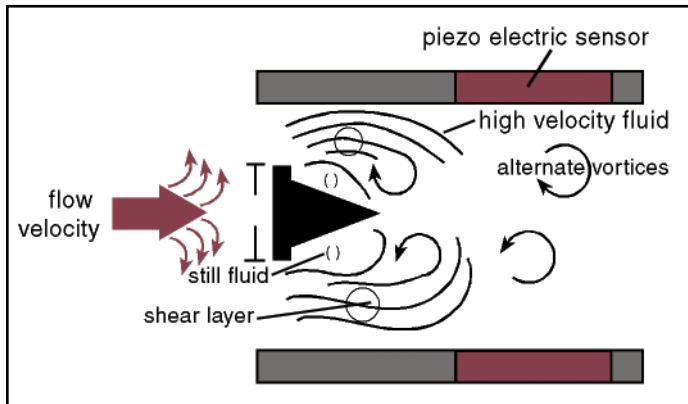

TABLE 53 - PERFORMANCE SPECIFICATIONS

FLOW ACCURACY	1% of rate.
FLOW REPEATABILITY	0.25% of rate.
FLOW TURNDOWN RATIO	See Tables 57 to 61.
RESPONSE TIME	Adjustable based on NRF and Damping settings (minimum 1000 ms).
DAMPING	Adjustable: 1 to 99 sec.
VELOCITY RANGE	Liq.: 1.32 or to 30 ft/sec. Steam & Gas: $(144/\bar{n})^{1/3}$ to 250 ft/sec. \bar{n} = density (lb/ft ³). d = pipe diameter (in). μ = viscosity (cp).
AGENCY APPROVALS*	FM and CSA Class 1 Div 2 Groups B,C,D.

TABLE 54 - PHYSICAL SPECIFICATION

** MATERIALS OF CONSTRUCTION	
SHEDDER BAR	316 SS.
ELECTRODES	316 SS encapsulated ceramic.
METERING TUBE	316 SS.
FLANGES	316L SS.
ELECTRONICS HOUSING	Epoxy coated aluminum.
CONNECTIONS AND MOUNTINGS	
MOUNTING POSITION	Vertical, horizontal, angle.
TYPICAL STRAIGHT PIPE REQUIREMENTS	Upstream: 20 x D. Downstream: 5 x D.
TEMPERATURE TAP (BY CUSTOMER)	Downstream: 3.5 x D.
PRESSURE TAP (BY CUSTOMER)	Upstream: 3.5 x D.
PROCESS CONNECTIONS	ANSI Class 150 RF, 300 RF, 600 RF, Wafer.
ELECTRICAL CONNECT	3/4" FNPT.

TABLE 55 - ELECTRONIC SPECIFICATIONS

AMBIENT TEMPERATURE	-12° to 65 °C (-15° to 149 °F).
TRANSMITTER	Microprocessor-based.
DISPLAY	Two lines, 16 alphanumeric characters each, programmable for different process variable rate and total.
FUNCTIONS	Measuring Units, Programmable Flow Alarm, Two Programmable Totalizers, Programmable Flow Rate Pulse Output, Two Programmable Optically Isolated Outputs, Two Programmable analog 4-20 mA outputs, Battery Backed Real Time Clock [RTC], Digital communication interface (RS-232 or RS-485), Programmable Diagnostic events Log and register with date and time stamp, Programmable Process Variable Data Log (total 15872 records) with date and time stamp, Calibration and Flowing Fluid parameters adjustment, Extensive Diagnostic.
OUTPUT SIGNAL	Two programmable analog 4-20 mA into 600 Ohms or less load, two programmable digital optically isolated (UCE @ 40Vdc, ICE @ 150 mA), one programmable optically isolated flow pulse output (UCE @ 60Vdc, ICE @ 50 mA).
ENCLOSURE PROTECTION	NEMA 4X.
ENCLOSURE APPROVALS	UL, CSA, FM Class I Groups B, C, D Class II Groups E, F, G KEMA/CENELEC EEX D IIB
POWER SUPPLY	15-30 Vdc standard 115 or 230 VAC (optional).

* Designed to meet.
Contact Aalborg for status of the agency approval.

**The selection of materials of construction, is the responsibility of the customer. The company accepts no liability.

Flow Ranges

Minimum and maximum flow rates to achieve accuracy in gal/min, L/min. Pipe ID based on schedule 80 steel.

TABLE 56 - WATER FLOW RATES AT 60 °F

SIZE (INCH)	3/4"		1"		1.5"		2"		3"		4"	
	min	max	min	max	min	max	min	max	min	max	min	max
gal/min	4	40.4	7	67.2	17	164.9	28	276.0	62	617.6	107	1075.3
L/min	15	152.9	25	254.3	62	624.4	104	1044.9	238	2337.9	407	4070.4

Minimum and maximum flow rates to achieve accuracy lb/hr. Pipe ID based on schedule 80 steel.

TABLE 57 - SATURATED STEAM FLOW RATES AT SELECTED PROCESS PRESSURES (English)

SIZE (INCH)	3/4"		1"		1.5"		2"		3"		4"	
	min	max	min	max	min	max	min	max	min	max	min	max
10	16.4	163.8	27.2	272.4	66.9	669.3	111.8	1118.3	250.2	2501.6	435.4	4354.1
25	25.5	255.3	42.5	424.7	104.3	1043.4	174.4	1743.5	390	3900.1	678.8	6788.4
50	40.4	403.6	67.1	671.4	165	1649.5	275.6	2756.3	616.5	6165.4	1073.1	10731.4
75	54.9	549.2	91.4	913.5	224.4	2244.3	375	3750.2	838.9	8388.7	1460.1	14601.1
100	69.3	693.2	115.3	1153.1	283.3	2832.8	473.4	4733.6	1058.8	10588.3	1843	18429.8
125	83.6	836.2	139.1	1391	341.7	3417.4	571.1	5710.5	1277.4	12773.6	2223.3	22233.4
150	97.9	978.7	162.8	1628	400	3999.7	668.3	6683.4	1495	14949.9	2602.1	26021.4
200	126.3	1262.8	210.1	2100.6	516.1	5160.7	862.4	8623.5	1929	19289.7	3357.5	33575.2
250	154.7	1546.9	257.3	2573.2	632.2	6321.6	1056.3	10563.3	2362.9	23628.6	4112.8	41127.5
300	182.1	1821.1	302.9	3029.3	744.2	7442.1	1243.6	12435.7	2781.7	27817.1	4841.8	48417.8
350	211.7	2116.5	352.1	3520.7	865	8649.5	1445.3	14453.3	3233	32330	5627.3	56273
400	241.3	2413.1	401.4	4014.2	986.2	9861.8	1647.9	16478.9	3686.1	36861.2	6416	64159.9
450	271	2710.2	450.8	4508.3	1107.6	11075.8	1850.8	18507.6	4139.9	41399	7505.8	75058.2
500	300.8	3007.5	500.3	5002.9	1229.1	12290.7	2053.8	20537.6	4594	45940	7996.2	79962.2
550	330.5	3305.2	549.8	5498.1	1350.7	13507.3	2257.1	22570.6	5048.7	50487.4	8787.7	87877.4
600	360.4	3603.8	599.5	5994.9	1472.8	14727.8	2461	24609.9	5504.9	55049.2	9581.7	95817.5

Minimum and maximum flow rates to achieve accuracy in (kg/hr) Pipe ID based on schedule 80 steel.

TABLE 58 - SATURATED STEAM FLOW RATES AT SELECTED PROCESS PRESSURES (METRIC)

Size (mm)	20		25		40		50		80		100	
	min	max	min	max	min	max	min	max	min	max	min	max
1	4.6	45.6	7.6	75.8	18.6	186.2	31.1	311.2	69.6	696.1	121.2	1211.6
2	8.7	87.4	14.6	145.5	35.7	357.4	59.7	597.1	133.6	1335.7	232.5	2324.9
4	16.7	167.4	27.8	278.4	68.4	683.9	114.3	1142.8	255.6	2556.3	445	4449.5
6	24.5	245.2	40.8	407.8	100.2	1001.9	167.4	1674.2	374.5	3744.9	651.8	6518.3
10	39.8	398.2	66.2	662.4	162.7	1627.3	271.9	2719.3	608.3	6082.6	1058.7	10587.3
14	55	549.9	91.5	914.7	224.7	2247.2	375.5	3755.1	840	8399.6	1462	14620.2
18	70.1	701.4	116.7	1166.7	286.6	2866.4	479	4789.7	1071.4	10713.9	1864.9	18648.5
22	84.9	849.3	141.3	1412.8	347.1	3470.8	580	5799.6	1297.3	12972.9	2258.1	22580.5
26	100.7	1007.1	167.5	1675.3	411.6	4115.7	687.7	6877.3	1538.4	15383.6	2677.6	26776.4
28	108.6	1086.2	180.7	1806.9	443.9	4439.2	741.8	7417.8	1659.3	16592.6	2888.1	28880.7
30	116.6	1165.5	193.9	1938.7	476.3	4762.9	795.9	7958.7	1780.3	17802.6	3098.7	30986.9
32	124.5	1244.7	207.1	2070.5	508.7	5086.8	850	8499.9	1901.3	19013.2	3309	33094
34	132.4	1324	220.2	2202.4	541.1	5410.8	904.1	9041.3	2022.4	20224.2	3520.2	35201.9
36	140.3	1403.3	233.4	2334.4	573.5	5735	958.3	9583	2143.6	21436	3731.1	37311.1
38	148.3	1482.7	246.7	2466.5	606	6059.5	1012.5	10125.3	2264.9	22649	3942.3	39422.5
40	156.2	1562.3	259.9	2598.8	638.5	6384.6	1066.9	10668.5	2386.4	23864.1	4153.7	41537.4

Minimum and maximum flow rates to achieve accuracy in CFPM (14.7 psia 70 °F) CFM at actual process temperature = min. or max values below *530/ (Actual Temp. (°F) + 460) Pipe ID based on schedule 80 steel. Flow Temp. 70 °F.

TABLE 59 - AIR FLOW RATES AT SELECTED PROCESS PRESSURES (English)

Size (inch)		3/4"		1"		1.5"		2"		3"		4"	
Density (lb/ft3)	Pressure (psig)	min	max	min	max	min	max	min	max	min	max	min	max
0.076	0	5	45.0	8	74.9	18	183.8	31	307.5	69	688.1	120	1197.9
0.103	5	6	60.3	10	100.3	25	246.3	41	412.1	92	922.1	160	1605.3
0.128	10	8	75.6	13	125.8	31	308.8	52	516.7	116	1156.1	201	2012.8
0.180	20	11	106.2	18	176.7	43	433.8	73	725.9	162	1624.2	283	2827.7
0.232	30	14	136.8	23	227.6	56	558.8	94	935.1	209	2092.2	364	3642.6
0.284	40	17	167.4	28	278.5	68	683.8	114	1144.2	256	2560.3	446	4457.5
0.336	50	20	198.1	33	329.4	81	808.8	135	1353.4	303	3028.4	527	5272.4
0.388	60	23	228.7	38	380.4	93	933.8	156	1562.6	350	3496.4	609	6087.3
0.440	70	26	259.3	43	431.3	106	1058.8	177	1771.8	396	3964.5	690	6902.2
0.493	80	29	289.9	48	482.2	118	1183.8	198	1981.0	443	4432.5	718	7717.1
0.545	90	32	320.5	53	533.1	131	1308.8	219	2190.2	490	4900.6	853	8532.0
0.596	100	35	351.1	58	584.0	143	1433.8	240	2399.3	537	5368.7	935	9346.9
0.649	110	38	381.7	64	635.0	156	1558.8	261	2608.5	584	5836.7	1016	10161.8
0.700	120	41	412.3	69	685.9	168	1683.8	282	2817.7	630	6304.8	1098	10976.7
0.752	130	44	443.0	74	736.8	181	1808.8	303	3026.9	677	6772.8	1179	11791.6
0.804	140	47	473.6	79	787.7	193	1933.8	324	3236.1	724	7240.9	1261	12606.5
0.856	150	50	504.2	84	838.6	206	2058.8	344	3445.3	771	7709.0	1342	13421.4
1.116	200	66	657.2	109	1093.2	268	2683.8	449	4491.2	1005	10049.3	1750	17495.9
1.636	300	96	963.4	160	1602.4	393	3933.8	658	6583.0	1473	14729.9	2564	25644.8

Minimum and maximum flow rates to achieve accuracy in M3/min (°C, 1.013 bar). M3/min at actual process temperature = minimum or maximum values below x 273 (actual temp (°C) + 273). Pipe ID based on schedule 80 steel. Flow Temp 0 °C.

TABLE 60 - AIR FLOW RATES AT SELECTED PROCESS PRESSURES (Metric)

Size (mm)		20		25		40		50		80		100	
Density (kg/m3)	Pressure (barg)	min	max	min	max	min	max	min	max	min	max	min	max
1.293	0	0.1	1.28	0.2	2.10	0.5	5.21	0.9	8.69	1.9	19.48	3.4	33.92
1.93	0.5	0.2	1.91	0.3	3.14	0.8	7.78	1.3	12.97	2.9	29.08	5.1	50.66
2.568	1	0.3	2.54	0.4	4.18	1.0	10.35	1.7	17.26	3.9	38.69	6.8	67.39
3.844	2	0.4	3.81	0.6	6.25	1.5	15.49	2.6	25.8	5.8	57.90	10.1	100.85
5.12	3	0.5	5.07	0.8	8.33	2.0	20.64	3.4	34.39	7.7	77.11	13.4	134.31
6.39	4	0.6	6.33	1.0	10.40	2.6	25.78	4.3	42.96	9.6	96.32	16.8	167.77
7.67	5	0.8	7.59	1.2	12.48	3.1	30.92	5.2	51.53	11.6	115.54	20.1	201.24
8.95	6	0.9	8.86	1.5	14.55	3.6	36.06	6.0	60.10	13.5	134.75	23.5	234.70
10.22	7	1.0	10.12	1.7	16.62	4.1	41.20	6.9	68.67	15.4	153.96	26.8	268.16
11.5	8	1.1	11.38	1.9	18.70	4.6	46.34	7.7	77.24	17.3	173.17	30.2	301.63
12.77	9	1.2	12.64	2.1	20.77	5.1	51.48	8.6	85.80	19.2	192.38	33.5	335.09
14.05	10	1.4	13.91	2.3	22.85	5.7	56.62	9.4	94.37	21.2	211.59	36.9	368.55
15.32	11	1.5	15.17	2.5	24.92	6.2	61.76	10.3	102.94	23.0	230.81	40.2	402.01
16.6	12	1.6	16.43	2.7	27.00	6.7	66.91	11.1	111.51	25.0	250.02	43.5	435.48
17.88	13	1.8	17.70	2.9	29.07	7.2	72.05	12.0	120.08	26.9	269.23	46.9	468.94
19.15	14	1.9	18.96	3.1	31.15	7.7	77.19	12.9	128.65	28.8	288.44	50.2	502.40
22.98	17	2.2	22.75	3.7	37.37	9.3	92.61	15.4	154.35	34.6	346.08	60.3	602.79
26.81	20	2.6	26.54	4.4	43.59	10.1	108.04	18.0	180.06	40.4	403.71	70.3	703.18

ANSI Flange Pressure - Temperature Ratings.
Maximum Pressure in psig.

TABLE 61 - FLOW METER PRESSURE RATING

MATERIAL	TEMP. °F				
	-100 to 100	200	300	400	500
316L SS 150# RF	230	195	175	160	145
316L SS 300# RF	600	505	455	415	380
316L SS 600# RF	1000	1000	910	825	765

ANSI Flange Pressure - Temperature Ratings.

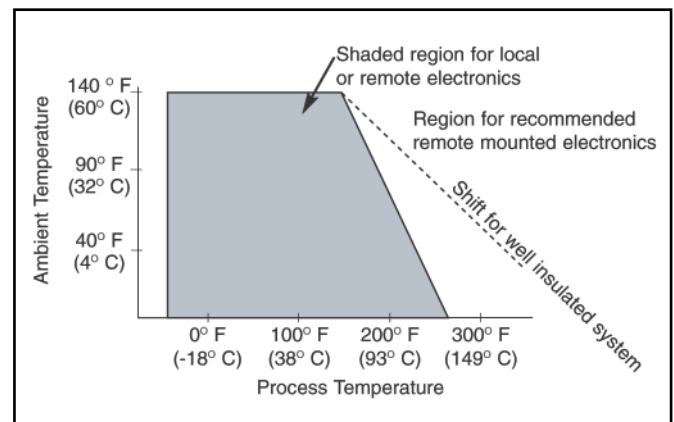
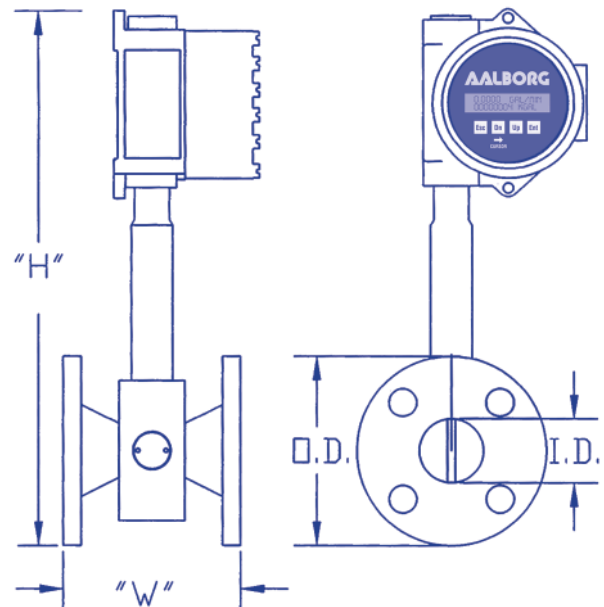

TABLE 62

Meter Size	Flange Rating	Bolt diameter	Bolts	I.D.	O.D.	"W"	"H"
in.	psi	in.	no.	in.	in.	in.	in.
3/4	150	1/2	4	0.742	3.875	5.88	9.75
	300	5/8	4		4.625	6.25	10.125
	600	5/8	4		4.625	6.25	10.125
	900	7/8	4		5.125	7.25	10.375
1	150	1/2	4	0.957	4.25	6.13	9.95
	300	5/8	4		4.875	6.63	10.27
	600	5/8	4		4.875	6.63	10.27
	900	1	4		5.875	7.5	10.76
1.5	150	1/2	4	1.50	5.00	6.63	10.35
	300	3/4	4		6.125	7.13	10.91
	600	3/7	4		6.125	7.25	10.91
	900	1-1/8	4		7.00	8.25	11.35
2	150	5/8	4	1.937	6.00	6.75	10.875
	300	5/8	4		6.50	7.25	11.125
	600	5/8	4		6.50	7.50	11.125
	900	1	4		8.50	9.75	12.125
3	150	5/8	4	2.900	7.50	7.25	11.60
	300	3/4	8		8.25	8.00	11.98
	600	3/4	8		8.25	8.25	11.98
	900	1	8		9.50	9.75	12.60
4	150	5/8	4	3.826	9.00	8.25	12.37
	300	3/4	8		10.00	9.00	12.87
	600	7/8	8		10.75	10.25	13.25
	900	1-1/4	8		11.50	11.285	13.62

Flange Mounting



Wafer Mounting

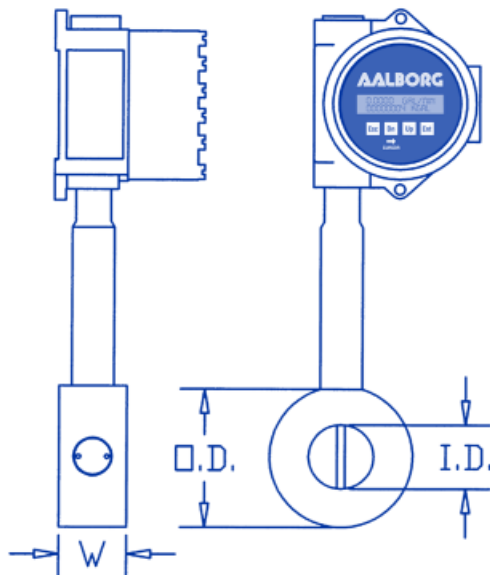

TABLE 63

Meter Size	Flange Rating	Bolt diameter	Bolts	I.D.	O.D.	"W"	"H"
in.	psi	in.	no.	in.	in.	in.	in.
3/4	150	1/2	4	0.742	2.370	2	9.00
	300	5/8	4				
	600	5/8	4				
1	150	1/2	4	0.957	2.740	2	9.20
	300	5/8	4				
	600	5/8	4				
1.5	150	1/2	4	1.500	3.500	2	9.60
	300	3/4	4				
	600	3/4	4				
2	150	5/8	4	1.937	4.250	2	10.00
	300	5/8	8				
	600	5/8	8				
3	150	5/8	4	2.900	5.497	2	10.60
	300	3/4	8				
	600	3/4	8				
4	150	5/8	8	3.826	6.997	2.5	11.37
	300	3/4	8				
	600	7/8	8				

To allow us to confirm selection please return completed application data sheet found on Aalborg's web site at www.aalborg.com.

1. Select style (wafer or flange).
2. Select meter size to match internal pipe diameter
3. Confirm minimum and maximum flow ranges to maintain stated accuracy from liquid, steam, or air from Tables 69 to 73 are within your requirements.
4. For other gas applications consult factory.
5. Select fluid type.
6. Select maximum temperature capability.
7. Select desired **Material of Construction.
8. Select mounting connection.
9. Confirm maximum pressure capability of flange/meter rating with process conditions and select flange rating from Table 74
10. Confirm suitability of standard local mounted electronics.
11. Select desired transmitter power.
12. Provide: Fluid, Fluid Viscosity, Minimum & Maximum Operating Pressure, Minimum & Maximum Operating Temperature, Density/Specific Gravity or Specific Volume.
13. Provide minimum and maximum flow range.

Options: Remote mount electronics up to 100 ft. (30.5 m).

† = Wafer and Flange Style for Alignment Ring Selection.

** = The selection of materials of construction, is the responsibility of the customer. The company accepts no liability.

VX	MODEL
	STYLE
U	Wafer
W	Wafer
E	Flange
F	Flange

SIZE: WAFER or FLANGE	
07	3/4" (20mm)
10	1.0" (25mm)
15	1.5" (40mm)
20	2.0" (50mm)
30	3.0" (80mm)
40	4.0" (100mm)

FLUID TYPE	
G	Gas
L	Liquid
S	Steam

MAX TEMP.	
4	450 °F

MATERIAL	
6	316 SS

MOUNTING CONNECTION	
A	Wafer. Using Customer Flanges
B	Flange Mounting
F	Other

FLANGE RATING†	
A	150# ANSI RF (Alignment Rings Not Required for Wafer Style)
B	300# ANSI RF (Wafer Style Includes Alignment Rings)
C	600# ANSI RF (Wafer Style Includes Alignment Rings)
D	Other
N	None

DISPLAY	
L2	Local with RS232
R2	Remote with RS232
L4	Local with RS485
R4	Remote with RS425

POWER	
04	24VDC
12	120VAC
22	220VAC

VX W — 10 L — 4 6 A B — L2 22

EXAMPLE: VXW-10L-44AB-L222

SPECIFY: FLUID NAME or MEASURING DENSITY, FLOW RATE, TEMPERATURE and PRESSURE (STEAM, GASES).

Vortex meter, Wafer style, 10" diameter size, Liquid at maximum 450 °F, 316 stainless steel, Customer flanges, Flange 300# ANSI RF, Local display with RS232, 220V power.

Design Features

- Temperature, pressure, density, volumetric and mass flow measurements.
- No moving parts to wear or fail.
- Electronics can be remotely mounted up to 30.5 m (100 ft).
- No fluid to sensor contact.
- No holes to clog.
- High flow turndown ratio up to 10:1.
- Dual signal processing technology improves accuracy at low flows.
- Accuracy of 1% of rate.
- Noise cancellation technology.
- Built in platinum RTD and solid state pressure sensor.
- On board computer calculates density, volumetric and mass flow.
- Aalborg's proprietary DSP algorithm accurately filters vortex frequency.
- Extensive Diagnostics log with date and time register.
- Password protected data entry.
- Volumetric and mass flow information simultaneously displayed.
- Selectable engineering units.
- Two programmable totalizers.
- Digital communication interface: RS-232 or RS-485.

Principles of Operation

Vortices are created when a fluid passes around a bluff body as shown in Figure 1. Vortices are alternately shed on each side of the body, 180 degrees out of phase to each other, resulting in an oscillating pressure gradient. As flow increases the frequency of vortices increases in proportion to the increased flow thereby creating a linear relationship.

General Description

Constructed of type 316 stainless steel, wafers may be installed in-line by customer provided or built-in flanges. Key pad or communication interface functionalities include measuring units, programmable flow alarm, two programmable totalizers, programmable flow rate pulse output, two programmable optically isolated outputs, battery backed real time clock (RTC), digital communication interface (RS-232 or RS-485), programmable diagnostic events log and register with date and time stamp, programmable process variable log with date stamp, calibration and flowing fluid parameters adjustment, extensive diagnostics.

Our exclusive dual signal processing technology independently measures each vortex on either side of the bluff body and filters out non-flow noise. This results in less noise and higher accuracy throughout the flow range. Aalborg's proprietary DSP algorithm accurately filters vortex frequency, improving the quality of flow measurements.

Local 2x16 LCD readout provides flow rate and total flow volume reading in selectable engineering units, diagnostic events indication and feature a password protected access to the process parameters to ensure against tampering or resetting.



Vortex In-line Flow Meter Shown with Wafer Mounting

Vortex In-line Flow Meter Shown with Flange Mounting

TABLE 64 - FUNCTIONAL SPECIFICATIONS

FLUID TYPES	Steam, Gas, Liquid.
MAXIMUM PRESSURE	69 bar (1000 psig) with wafer mount See Table 74 for flange mount.
FLUID TEMPERATURE	-20 °F to 232 °C. -4 °F to 450 °F.
LOW FLOW CUT-OFF	Adjustable: Set @ min. per Tables 69 to 73.
HIGH FLOW CUT-OFF	Adjustable: Set @ max. per Tables 69 to 73.
VOLTAGE	15 to 30 Vdc standard. 115 or 230 VAC optional.
FREQUENCY	50 /60 Hz.
OUTPUTS	Two user programmable analog 4-20 mA outputs (600 Ohms or less load). Each can be assigned to one of the following process variables: volumetric flow, mass flow, temperature or pressure. Two sets of user programmable digital optically isolated outputs to actuate user supplied equipment when various diagnostic or system events occurs. One user programmable optically isolated flow pulse output, RS-232 or RS-485 Digital Interface with Multi-Drop Capability of up to 255 units (RS-485 option).
LINEAR RANGE	Reynolds number of >10,000.

TABLE 65 - PERFORMANCE SPECIFICATIONS

FLOW ACCURACY	1% of rate.
FLOW REPEATABILITY	0.25% of rate.
FLOW TURNDOWN RATIO	See Tables 69 to 73.
RESPONSE TIME	Adjustable based on NRF and Damping settings (minimum 1000 ms).
DAMPING	Adjustable: 1 to 99 sec.
VELOCITY RANGE	Liq.: 1.32 or $\frac{10000\mu}{\bar{n}d \cdot 124}$ to 30 ft/sec. Steam & Gas: $(144/\bar{n})^{1/3}$ to 250 ft/sec. \bar{n} = density (lb/ft ³). d= pipe diameter (in). μ = viscosity (cp).
AGENCY APPROVALS*	FM and CSA Class 1 Div 2 Groups B,C,D.
FLUID TEMPERATURE MEASUREMENT RANGE	20 to 260 °C (-4 to 450 °F).
TEMPERATURE ACCURACY (INCLUDING LINEARITY)	0.5 °C.
FLUID PRESSURE MEASUREMENT RANGE	Can be ordered for the following options: 0-100 PSIA. 0-200 PSIA. 0-300 PSIA. 0- 500 PSIA. 0-750 PSIA. 0-1000 PSIA.
PRESSURE ACCURACY (INCLUDING LINEARITY)	0.5% of full scale.
FLUID PROOF PRESSURE	3 X F.S.
FLUID BURST PRESSURE	10 X F.S.

TABLE 66 - PHYSICAL SPECIFICATION

**MATERIALS OF CONSTRUCTION	
SHEDDER BAR	316 SS.
ELECTRODES	316 SS encapsulated ceramic.
METERING TUBE	316 SS.
FLANGES	316 SS.
ELECTRONICS HOUSING	Epoxy coated aluminum.
CONNECTIONS AND MOUNTINGS	
MOUNTING POSITION	Vertical, horizontal, angle.
TYPICAL STRAIGHT PIPE REQUIREMENTS	Upstream: 20 x D. Downstream: 5 x D.
PROCESS CONNECTIONS	ANSI Class 150 RF, 300 RF, 600 RF, Wafer.
ELECTRICAL CONNECT	3/4" FNPT.

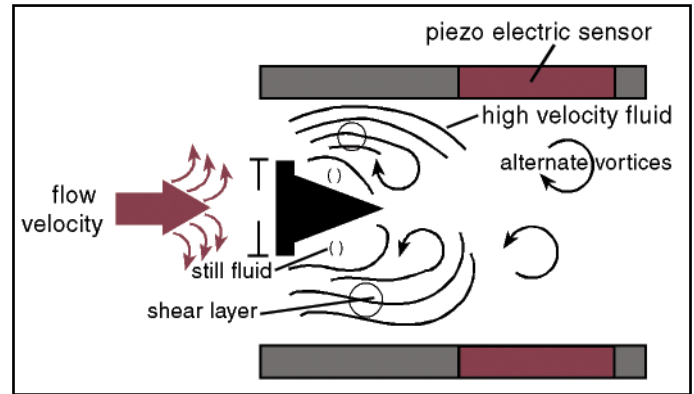

TABLE 67 - ELECTRONIC SPECIFICATIONS

AMBIENT TEMPERATURE	-12F to 65 °C (-15F to 149 °F).
TRANSMITTER	Microprocessor-based.
DISPLAY	Two lines, 16 alphanumeric characters each, programmable for different process variable rate and total.
FUNCTIONS	Measuring Units, Programmable Flow, Temperature and Pressure Alarms, Two Programmable Totalizers, Programmable Flow Rate Pulse Output, Two Programmable Optically Isolated Outputs, Two Programmable analog 4-20 mA outputs, Battery Backed Real Time Clock [RTC], Digital communication interface (RS-232 or RS-485), Programmable Diagnostic events Log and register with date and time stamp, Programmable Process Variable Data Log (total 15872 records) with date and time stamp, Calibration and Flowing Fluid parameters adjustment, Extensive Diagnostic.
OUTPUT SIGNAL	Two programmable analog 4-20 mA into 600 Ohms or less load, two programmable digital optically isolated (UCE @ 40Vdc, ICE @ 150 mA), one programmable optically isolated flow pulse output (UCE @ 60Vdc, ICE @ 50 mA).
ENCLOSURE PROTECTION	NEMA 4X.
ENCLOSURE APPROVALS	UL, CSA, FM Class I Groups B, C, D Class II Groups E, F, G KEMA/CENELEC EEx d IIB
POWER SUPPLY	15-30 Vdc standard 115 or 230 VAC (optional).

* Designed to meet.
Contact Aalborg for status of the agency approval.

**The selection of materials of construction, is the responsibility of the customer. The company accepts no liability.

Flow Ranges

Minimum and maximum flow rates to achieve accuracy in gal/min, L/min. Pipe ID based on schedule 80 steel.

TABLE 68 - WATER FLOW RATES AT 60 °F

SIZE (INCH)		3/4"		1"		1.5"		2"		3"		4"	
		min	max	min	max	min	max	min	max	min	max	min	max
gal/min	4	40.4	7	67.2	17	164.9	28	276.0	62	617.6	617.6	107	1075.3
L/min	15	152.9	25	254.3	62	624.4	104	1044.9	238	337.9	2337.9	407	4070.4

Minimum and maximum flow rates to achieve accuracy lb/hr. Pipe ID based on schedule 80 steel.

TABLE 69 - SATURATED STEAM FLOW RATES AT SELECTED PROCESS PRESSURES (English)

SIZE (INCH)	3/4"		1"		1.5"		2"		3"		4"	
PRESSURE (psig)	min	max	min	max	min	max	min	max	min	max	min	max
10	16.4	163.8	27.2	272.4	66.9	669.3	111.8	1118.3	250.2	2501.6	435.4	4354.1
25	25.5	255.3	42.5	424.7	104.3	1043.4	174.4	1743.5	390	3900.1	678.8	6788.4
50	40.4	403.6	67.1	671.4	165	1649.5	275.6	2756.3	616.5	6165.4	1073.1	10731.4
75	54.9	549.2	91.4	913.5	224.4	2244.3	375	3750.2	838.9	8388.7	1460.1	14601.1
100	69.3	693.2	115.3	1153.1	283.3	2832.8	473.4	4733.6	1058.8	10588.3	1843	18429.8
125	83.6	836.2	139.1	1391	341.7	3417.4	571.1	5710.5	1277.4	12773.6	2223.3	22233.4
150	97.9	978.7	162.8	1628	400	3999.7	668.3	6683.4	1495	14949.9	2602.1	26021.4
200	126.3	1262.8	210.1	2100.6	516.1	5160.7	862.4	8623.5	1929	19289.7	3357.5	33575.2
250	154.7	1546.9	257.3	2573.2	632.2	6321.6	1056.3	10563.3	2362.9	23628.6	4112.8	41127.5
300	182.1	1821.1	302.9	3029.3	744.2	7442.1	1243.6	12435.7	2781.7	27817.1	4841.8	48417.8
350	211.7	2116.5	352.1	3520.7	865	8649.5	1445.3	14453.3	3233	32330	5627.3	56273
400	241.3	2413.1	401.4	4014.2	986.2	9861.8	1647.9	16478.9	3686.1	36861.2	6416	64159.9
450	271	2710.2	450.8	4508.3	1107.6	11075.8	1850.8	18507.6	4139.9	41399	7505.8	75058.2
500	300.8	3007.5	500.3	5002.9	1229.1	12290.7	2053.8	20537.6	4594	45940	7996.2	79962.2
550	330.5	3305.2	549.8	5498.1	1350.7	13507.3	2257.1	22570.6	5048.7	50487.4	8787.7	87877.4
600	360.4	3603.8	599.5	5994.9	1472.8	14727.8	2461	24609.9	5504.9	55049.2	9581.7	95817.5

Minimum and maximum flow rates to achieve accuracy in (kg/hr) Pipe ID based on schedule 80 steel.

TABLE 70 - SATURATED STEAM FLOW RATES AT SELECTED PROCESS PRESSURES (Metric)

Size (mm)	20		25		40		50		80		100	
Pressure (bara)	min	max	min	max	min	max	min	max	min	max	min	max
1	4.6	45.6	7.6	75.8	18.6	186.2	31.1	311.2	69.6	696.1	121.2	1211.6
2	8.7	87.4	14.6	145.5	35.7	357.4	59.7	597.1	133.6	1335.7	232.5	2324.9
4	16.7	167.4	27.8	278.4	68.4	683.9	114.3	1142.8	255.6	2556.3	445	4449.5
6	24.5	245.2	40.8	407.8	100.2	1001.9	167.4	1674.2	374.5	3744.9	651.8	6518.3
10	39.8	398.2	66.2	662.4	162.7	1627.3	271.9	2719.3	608.3	6082.6	1058.7	10587.3
14	55	549.9	91.5	914.7	224.7	2247.2	375.5	3755.1	840	8399.6	1462	14620.2
18	70.1	701.4	116.7	1166.7	286.6	2866.4	479	4789.7	1071.4	10713.9	1864.9	18648.5
22	84.9	849.3	141.3	1412.8	347.1	3470.8	580	5799.6	1297.3	12972.9	2258.1	22580.5
26	100.7	1007.1	167.5	1675.3	411.6	4115.7	687.7	6877.3	1538.4	15383.6	2677.6	26776.4
28	108.6	1086.2	180.7	1806.9	443.9	4439.2	741.8	7417.8	1659.3	16592.6	2888.1	28880.7
30	116.6	1165.5	193.9	1938.7	476.3	4762.9	795.9	7958.7	1780.3	17802.6	3098.7	30986.9
32	124.5	1244.7	207.1	2070.5	508.7	5086.8	850	8499.9	1901.3	19013.2	3309	33094
34	132.4	1324	220.2	2202.4	541.1	5410.8	904.1	9041.3	2022.4	20224.2	3520.2	35201.9
36	140.3	1403.3	233.4	2334.4	573.5	5735	958.3	9583	2143.6	21436	3731.1	37311.1
38	148.3	1482.7	246.7	2466.5	606	6059.5	1012.5	10125.3	2264.9	22649	3942.3	39422.5
40	156.2	1562.3	259.9	2598.8	638.5	6384.6	1066.9	10476.7	2386.4	23864.1	4153.7	41537.4

Minimum and maximum flow rates to achieve accuracy in CFPM (14.7 psia 70 °F) CFM at actual process temperature = min. or max values below *530/ (Actual Temp. (°F) + 460) Pipe ID based on schedule 80 steel. Flow Temp. 70 °F.

TABLE 71 - AIR FLOW RATES AT SELECTED PROCESS PRESSURES (English)

Size (inch)		3/4"		1"		1.5"		2"		3"		4"	
Density (lb/ft3)	Pressure (psig)	min	max	min	max	min	max	min	max	min	max	min	max
0.076	0	5	45.0	8	74.9	18	183.8	31	307.5	69	688.1	120	1197.9
0.103	5	6	60.3	10	100.3	25	246.3	41	412.1	92	922.1	160	1605.3
0.128	10	8	75.6	13	125.8	31	308.8	52	516.7	116	1156.1	201	2012.8
0.180	20	11	106.2	18	176.7	43	433.8	73	725.9	162	1624.2	283	2827.7
0.232	30	14	136.8	23	227.6	56	558.8	94	935.1	209	2092.2	364	3642.6
0.284	40	17	167.4	28	278.5	68	683.8	114	1144.2	256	2560.3	446	4457.5
0.336	50	20	198.1	33	329.4	81	808.8	135	1353.4	303	3028.4	527	5272.4
0.388	60	23	228.7	38	380.4	93	933.8	156	1562.6	350	3496.4	609	6087.3
0.440	70	26	259.3	43	431.3	106	1058.8	177	1771.8	396	3964.5	690	6902.2
0.493	80	29	289.9	48	482.2	118	1183.8	198	1981.0	443	4432.5	718	7717.1
0.545	90	32	320.5	53	533.1	131	1308.8	219	2190.2	490	4900.6	853	8532.0
0.596	100	35	351.1	58	584.0	143	1433.8	240	2399.3	537	5368.7	935	9346.9
0.649	110	38	381.7	64	635.0	156	1558.8	261	2608.5	584	5836.7	1016	10161.8
0.700	120	41	412.3	69	685.9	168	1683.8	282	2817.7	630	6304.8	1098	10976.7
0.752	130	44	443.0	74	736.8	181	1808.8	303	3026.9	677	6772.8	1179	11791.6
0.804	140	47	473.6	79	787.7	193	1933.8	324	3236.1	724	7240.9	1261	12606.5
0.856	150	50	504.2	84	838.6	206	2058.8	344	3445.3	771	7709.0	1342	13421.4
1.116	200	66	657.2	109	1093.2	268	2683.8	449	4491.2	1005	10049.3	1750	17495.9
1.636	300	96	963.4	160	1602.4	393	3933.8	658	6583.0	1473	14729.9	2564	25644.8

Minimum and maximum flow rates to achieve accuracy in M3/min (°C, 1.013 bar). M3/min at actual process temperature = minimum or maximum values below x 273 (actual temp (°C) + 273). Pipe ID based on schedule 80 steel. Flow Temp 0 °C.

TABLE 72 - AIR FLOW RATES AT SELECTED PROCESS PRESSURES (Metric)

Size (mm)		20		25		40		50		80		100	
Density (lb/ft3)	Pressure (psig)	min	max	min	max	min	max	min	max	min	max	min	max
1.293	0	0.1	1.28	0.2	2.10	0.5	5.21	0.9	8.69	1.9	19.48	3.4	33.92
1.93	0.5	0.2	1.91	0.3	3.14	0.8	7.78	1.3	12.97	2.9	29.08	5.1	50.66
2.568	1	0.3	2.54	0.4	4.18	1.0	10.35	1.7	17.26	3.9	38.69	6.8	67.39
3.844	2	0.4	3.81	0.6	6.25	1.5	15.49	2.6	25.82	5.8	57.90	10.1	100.85
5.12	3	0.5	5.07	0.8	8.33	2.0	20.64	3.4	34.39	7.7	77.11	13.4	134.31
6.39	4	0.6	6.33	1.0	10.40	2.6	25.78	4.3	42.96	9.6	96.32	16.8	167.77
7.67	5	0.8	7.59	1.2	12.48	3.1	30.92	5.2	51.53	11.6	115.54	20.1	201.24
8.95	6	0.9	8.86	1.5	14.55	3.6	36.06	6.0	60.10	13.5	134.75	23.5	234.70
10.22	7	1.0	10.12	1.7	16.62	4.1	41.20	6.9	68.67	15.4	153.96	26.8	268.16
11.5	8	1.1	11.38	1.9	18.70	4.6	46.34	7.7	77.24	17.3	173.17	30.2	301.63
12.77	9	1.2	12.64	2.1	20.77	5.1	51.48	8.6	85.80	19.2	192.38	33.5	335.09
14.05	10	1.4	13.91	2.3	22.85	5.7	56.62	9.4	94.37	21.2	211.59	36.9	368.55
15.32	11	1.5	15.17	2.5	24.92	6.2	61.76	10.3	102.94	23.0	230.81	40.2	402.01
16.6	12	1.6	16.43	2.7	27.00	6.7	66.91	11.1	111.51	25.0	250.02	43.5	435.48
17.88	13	1.8	17.70	2.9	29.07	7.2	72.05	12.0	120.08	26.9	269.23	46.9	468.94
19.15	14	1.9	18.96	3.1	31.15	7.7	77.19	12.9	128.65	28.8	288.44	50.2	502.40
22.98	17	2.2	22.75	3.7	37.37	9.3	92.61	15.4	154.35	34.6	346.08	60.3	602.79
26.81	20	2.6	26.54	4.4	43.59	10.1	108.04	18.0	180.06	40.4	403.71	70.3	703.18

*ANSI Flange Pressure - Temperature Ratings.
Maximum Pressure in psig.*

TABLE 73 - FLOW METER PRESSURE RATING

MATERIAL	TEMP. °F				
	-100 to 100	200	300	400	500
316L SS 150# RF	230	195	175	160	145
316L SS 300# RF	600	505	455	415	380
316L SS 600# RF	1000	1000	910	825	765

Ambient Temperature Range for Electronics

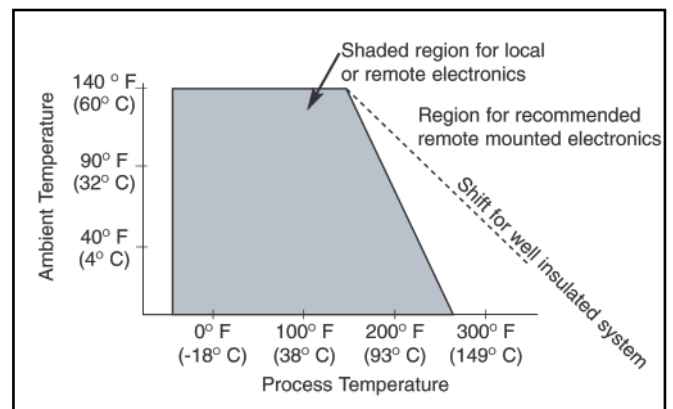

Flange Mounting

TABLE 74

Meter Size	Flange Rating	Bolt diameter	Bolts	I.D.	O.D.	"W"	"H"
in.	psi	in.	no.	in.	in.	in.	in.
3/4	150	1/2	4	0.742	3.875	FOR DIMENSIONS CONTACT AALBORG CUSTOMER SERVICE DEPARTMENT	9.75
	300	5/8	4		4.625		10.125
	600	5/8	4		4.625		10.125
	900	7/8	4		5.125		10.375
1	150	1/2	4	0.957	4.25		9.95
	300	5/8	4		4.875		10.27
	600	5/8	4		4.875		10.27
	900	1	4		5.875		10.76
1.5	150	1/2	4	1.50	5.00		10.35
	300	3/4	4		6.125		10.91
	600	3/7	4		6.125		10.91
	900	1-1/8	4		7.00		11.35
2	150	5/8	4	1.937	6.00	10.875	
	300	5/8	4		6.50	11.125	
	600	5/8	4		6.50	11.125	
	900	1	4		8.50	12.125	
3	150	5/8	4	2.900	7.50	11.60	
	300	3/4	8		8.25	11.98	
	600	3/4	8		8.25	11.98	
	900	1	8		9.50	12.60	
4	150	5/8	4	3.826	9.00	12.37	
	300	3/4	8		10.00	12.87	
	600	7/8	8		10.75	13.25	
	900	1-1/4	8		11.50	13.62	

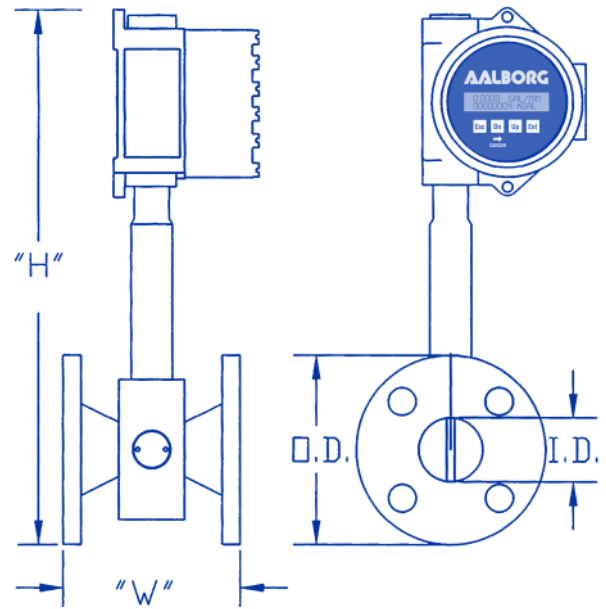

Wafer Mounting

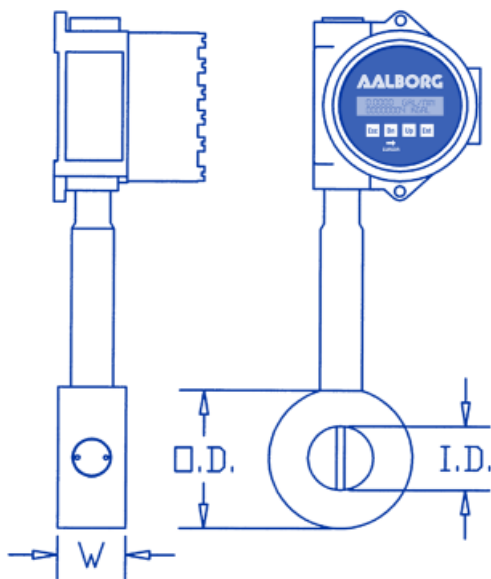

TABLE 75

Meter Size	Flange Rating	Bolt Diameter	Bolts	I.D.	O.D.	"W"	"H"
in.	psi	in.	no.	in.	in.	in.	in.
3/4	150	1/2	4	0.742	2.370	FOR DIMENSIONS CONTACT AALBORG CUSTOMER SERVICE DEPARTMENT	9.00
	300	5/8	4				
	600	5/8	4				
1	150	1/2	4	0.957	2.740		9.20
	300	5/8	4				
	600	5/8	4				
1.5	150	1/2	4	1.500	3.500		9.60
	300	3/4	4				
	600	3/4	4				
2	150	5/8	4	1.937	4.250		10.00
	300	5/8	8				
	600	5/8	8				
3	150	5/8	4	2.900	5.497	10.60	
	300	3/4	8				
	600	3/4	8				
4	150	5/8	8	3.826	6.997	11.37	
	300	3/4	8				
	600	7/8	8				

To allow us to confirm selection please return completed application data sheet found on Aalborg's web site at www.aalborg.com.

1. Select style (wafer or flange).
2. Select meter size to match internal pipe diameter.
3. Confirm minimum and maximum flow ranges to maintain stated accuracy from liquid, steam, or air from Tables 82 to 85 are within your requirements.
4. For other gas applications consult factory.
5. Select fluid type.
6. Select maximum temperature capability.
7. Select desired **Material of Construction.
8. Select mounting connection.
9. Confirm maximum pressure capability of flange/meter rating with process conditions and select flange rating from Table 81.
10. Confirm suitability of standard local mounted electronics.
11. Select desired transmitter power.
12. Provide: Fluid, Fluid Viscosity, Minimum & Maximum Operating Pressure, Minimum & Maximum Operating Temperature, Density/Specific Gravity or Specific Volume.
13. Provide minimum and maximum flow range.

† = Flange and Wafer Style for Alignment Ring Selection.

** = The selection of materials of construction, is the responsibility of the customer. The company accepts no liability.

VX	MODEL
----	-------

STYLE	
S	Wafer - SCH 40 Pressure, Temperature
T	Wafer - SCH 80 Pressure, Temperature
C	Flange - SCH 40 Pressure, Temperature
D	Flange - SCH 80 Pressure, Temperature

SIZE: WAFER or FLANGE	
07	3/4" (20mm)
10	1.0" (25mm)
15	1.5" (40mm)
20	2.0" (50mm)
30	3.0" (80mm)
40	4.0" (100mm)

FLUID TYPE	
G	Gas
L	Liquid
S	Steam

MAX TEMP. / PRESSURE	
A	450 °F / 100 PSIA
B	450 °F / 200 PSIA
C	450 °F / 300 PSIA
D	450 °F / 500 PSIA
E	450 °F / 750 PSIA
F	450 °F / 1000 PSIA

MATERIAL	
6	316 SS

MOUNTING CONNECTION	
A	Wafer. Using Customer Flanges
B	Flange Mounting
F	Other

FLANGE RATING†	
A	150# ANSI RF (Alignment Rings Not Required for Wafer Style)
B	300# ANSI RF (Wafer Style Includes Alignment Rings)
C	600# ANSI RF (Wafer Style Includes Alignment Rings)
D	Other
N	None

DISPLAY	
L2	Local with RS232
L4	Local with RS485

POWER	
04	24VDC
12	120VAC
22	220VAC

VX D 10 L F 6 A B L2 22

EXAMPLE: VXD-10L-46AB-L222

SPECIFY: FLUID NAME OR MEASURING DENSITY, FLOW RATE, TEMPERATURE AND PRESSURE (STEAM, GASES).

Vortex meter, Flange style, 1.0" diameter size, Liquid at maximum 450 °F, 1000 PSIA, 316 stainless steel, Customer flanges, Flange 300# ANSI RF, Local display with RS232, 220V power.

Design Features

- Wide range of available insertion inside diameter applications.
- Installation by porting into piping without need to lengthening line.
- Optional installation and servicing removal of meter without shutting off line.
- No moving parts to wear or fail
- Electronics can be remotely mounted up to 30.5 m (100 ft).
- No holes to clog.
- Aalborg's proprietary DSP algorithm accurately filters vortex frequency.
- High flow turndown ratio up to 10:1.
- Dual sensor signal processing technology improves accuracy at low flows.
- Accuracy of 1% of rate.
- Noise cancellation technology.
- Extensive Diagnostics.
- Password protected data entry.
- Volumetric and mass flow information simultaneously displayed.
- Selectable engineering units.
- On board computer calculates density and mass flow.
- Two programmable totalizers.

Vortex Insertion
Flow Meter Shown
with Fixed Mounting



Vortex Insertion
Flow Meter Shown
with Retractable Mounting



Principles of Operation

Vortices are created when a fluid passes around a bluff body as shown in Figure 1. Vortices are alternately shed on each side of the body, 180 degrees out of phase to each other, resulting in an oscillating pressure gradient. As flow increases the frequency of vortices increases in proportion to the increased flow thereby creating a linear relationship.

General Description

Constructed of type 316 stainless steel, Vortex meters may be inserted into pipe conduits carrying gases, liquids or steam. Insertion applications facilitate inside diameters from 4" to 12 feet!

By porting directly into piping, conduit lines need not be lengthened. Optional isolation valve permits installation, servicing, or removal of vortex meters without having to shut gas, liquid or steam processing operations.

Key pad or communication interface is provided to access the following parameters: measuring units; programmable flow alarm; two programmable totalizers; programmable flow rate pulse output; two programmable optically isolated outputs; battery backed real time clock (RTC); digital communication interface (RS-232 or RS-485); programmable diagnostic events log and register with date/time stamp; programmable process variable log with date/time stamp; calibration and flowing fluid parameters adjustment; extensive diagnostics.

Our exclusive dual signal processing technology independently measures each vortex on either side of the bluff body and filters out non-flow noise. This results in less noise and higher accuracy throughout the flow range. Aalborg's proprietary DSP algorithm accurately filters vortex frequency, improving the quality of flow measurements.

User preset temperature and pressure information processed by an on board computer to calculate density and mass flow. Local 2x16 LCD readout provides simultaneous volumetric and mass flow readings, total flow volume reading in selectable engineering units, diagnostic events indication, and password protected - user entered parameters.

TABLE 76 - FUNCTIONAL SPECIFICATIONS

FLUID TYPES	Steam, Gas, Liquid.
MAXIMUM PRESSURE	69 bar (1000 psig) with wafer mount See Table 81 for flange mount.
FLUID TEMPERATURE	-20 °F to 232 °C. -4° to 450 °F.
LOW FLOW CUT-OFF	Adjustable: Set @ min. per Tables 82 to 85.
HIGH FLOW CUT-OFF	Adjustable: Set @ max. per Tables 82 to 85.
VOLTAGE	15 to 30 Vdc standard. 115 or 230 VAC optional.
FREQUENCY	50 /60 Hz.
OUTPUTS	Two user programmable analog 4-20 mA outputs (600 Ohms or less load), two sets of user-programmable optically isolated outputs, one user programmable optically isolated flow pulse output, RS-232 or RS-485 Digital Interface with Multi-Drop Capability of up to 255 units (RS-485 option).
LINEAR RANGE	Reynolds number of >10,000.

TABLE 78 - PERFORMANCE SPECIFICATIONS

FLOW ACCURACY	±1% of rate.
FLOW REPEATABILITY	±0.25% of rate.
FLOW TURNDOWN RATIO	See Tables 82 to 85.
RESPONSE TIME	Adjustable based on NRF and Damping settings (minimum 1000 ms).
DAMPING	Adjustable: 1 to 99 sec.
VELOCITY RANGE	Liq.: 1.32 or to 30 ft/sec Steam & Gas: $(144/\bar{n})^{1/3}$ to 250 ft/sec \bar{n} = density (lb/ft ³) d= pipe diameter (in) μ = viscosity (cp)
AGENCY APPROVALS*	FM and CSA Class 1 Div 2 Groups B,C,D.

TABLE 79 - ELECTRONIC SPECIFICATIONS

AMBIENT TEMPERATURE	-12° to 65 °C (-15 °F to 149 °F).
TRANSMITTER	Microprocessor-based.
DISPLAY	Two lines, 16 alphanumeric characters each, programmable for different process variable rate and total.
FUNCTIONS	Measuring Units, Programmable Flow Alarm, Two Programmable Totalizers, Programmable Flow Rate Pulse Output, Two Programmable Optically Isolated Outputs, Two Programmable analog 4-20 mA outputs, Battery Backed Real Time Clock [RTC], Digital communication interface (RS-232 or RS-485*), Programmable Diagnostic events Log and register with date and time stamp, Programmable Process Variable Data Log (total 15872 records) with date and time stamp, Calibration and Flowing Fluid parameters adjustment, Extensive Diagnostic.
OUTPUT SIGNAL	Two programmable analog 4-20 mA into 600 Ohms or less load, two programmable digital optically isolated (UCE @ 40Vdc, ICE @ 150 mA), one programmable optically isolated flow pulse out put (UCE @ 60Vdc, ICE @ 50 mA).
ENCLOSURE PROTECTION	NEMA 4X.
ENCLOSURE APPROVALS	UL, CSA, FM Class I Groups B, C, D Class II Groups E, F, G KEMA/GENELEC Ex d IIB
POWER SUPPLY	15-30 Vdc standard, 115 or 230 VAC (optional).

**Designed to meet.
Contact Aalborg for status of the agency approval.*

TABLE 77 - PHYSICAL SPECIFICATIONS

**MATERIALS OF CONSTRUCTION	
SHEDDER BAR	316 SS.
ELECTRODES	316 SS encapsulated ceramic.
METERING TUBE	316 SS.
FLANGES	316L SS.
ELECTRONICS HOUSING	Epoxy coated aluminum.
CONNECTIONS AND MOUNTINGS	
MOUNTING POSITION	Vertical, horizontal, angle.
TYPICAL STRAIGHT PIPE REQUIREMENTS	Upstream: 20 x D. Downstream: 5 x D.
PROCESS CONNECTIONS	MNPT, ANSI Class 150 RF, 300 RF, 600 RF, Welded Flange.
ELECTRICAL CONNECT	3/4" FNPT.

***The selection of materials of construction, is the responsibility of the customer. The company accepts no liability.*

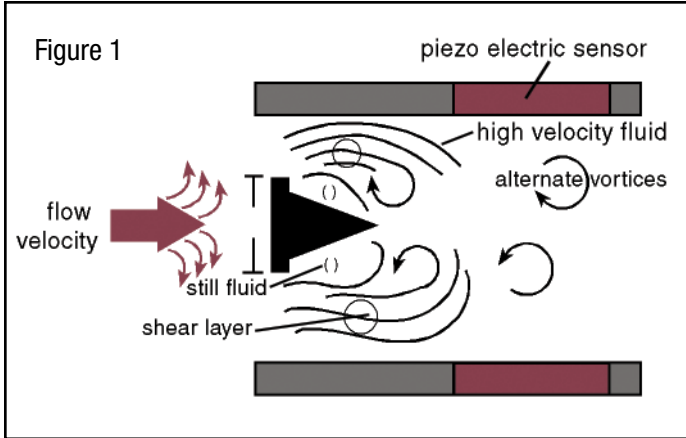
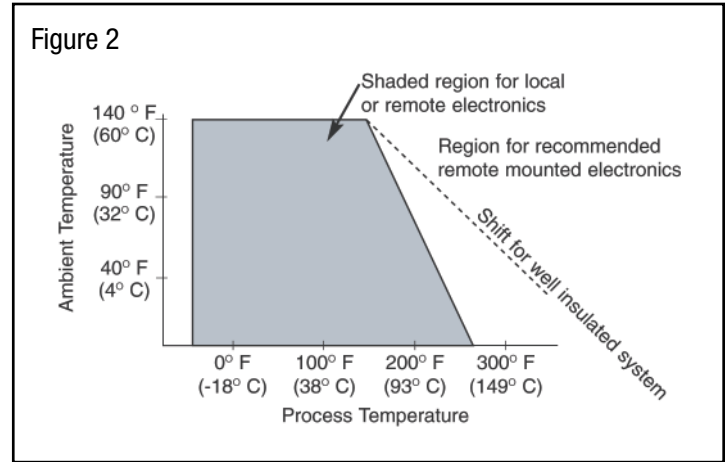

Figure 1
Dual signal processing technology independently measures each vortex providing increased accuracy and turndown.

Ambient Temperature Range for Electronics



Flow Meter Pressure Rating

ANSI Flange Pressure - Temperature Ratings. Maximum Pressure in psig.

TABLE 80 - FLOW METER PRESSURE RATING

MATERIAL	TEMP. °F					
	-100 to 100	200	300	400	500	600
316L SS 150# RF	230	195	175	160	145	140
316L SS 300# RF	600	505	455	415	380	360
316L SS 600# RF	1000	1000	910	825	765	720

Flow Ranges

Minimum and maximum flow rates to achieve accuracy. Pipe ID based on schedule 40 steel.

TABLE 81 - WATER FLOW RATES AT 70 °F

	4"		5"		6"		8"		10"		12"		14"	
	min	max	min	max	min	max	min	max	min	max	min	max	min	max
gal/min	119	1190.3	187	1871.6	270	2701.1	468	4675.0	737	7372.0	1047	10466.3	1265	12648.9
L/min	451	4505.6	708	7084.7	1022	10224.3	1770	17696.4	2791	27905.4	3962	39618.1	4788	47880.1

	16"		18"		20"		24"		30"		36"	
	min	max	min	max	min	max	min	max	min	max	min	max
gal/min	1652	16524.1	2091	20915.1	2599	25994.0	3760	37595.4	5965	59648.2	8740	87397
L/min	6255	62549.0	7917	79169.9	9840	98395.3	14231	142310.1	22579	225786.9	33083	330833.6



Minimum and maximum flow rates to achieve accuracy in (lb/hr).
Pipe ID based on schedule 40 steel.

TABLE 82 - SATURATED STEAM FLOW RATES AT SELECTED PROCESS PRESSURES (English)

Pressure (psig)	4"		6"		8"		10"		12"		14"		16"		18"		20"	
	min	max	min	max	min	max	min	max	min	max	min	max	min	max	min	max	min	max
10	482	4821	1094	10942	1895	18947	2986	4239	42392	42392	5124	51241	6693	66927	8472	84715	10527	105266
25	752	7517	1706	17058	2954	29539	4656	6609	66090	66090	7989	79887	10434	104342	13207	132073	16411	164114
50	1188	11883	2697	26967	4670	46696	7360	10448	104479	104479	12629	126289	16495	164949	20879	208788	25944	259440
75	1617	16168	3669	36691	6354	63535	10015	14215	142154	142154	17183	171828	22443	224429	28408	284077	35299	352993
100	2041	20407	4631	46312	8020	80195	12641	17943	179430	179430	21689	216885	28328	283279	35857	358567	45556	455555
125	2462	24619	5587	55870	9675	96746	15249	21646	216461	216461	26165	261647	34174	341742	43257	432569	53751	537510
150	2881	28813	6539	65389	11323	113228	17848	25334	253340	253340	30622	306224	39997	399966	50627	506268	62909	629087
200	3718	37177	8437	84371	14610	146098	23029	32688	326883	326883	39512	395119	51607	516074	65323	653233	81171	811707
250	4554	45540	10335	103349	17896	178961	28208	40041	400411	400411	48400	483995	63216	632157	80017	800169	99429	994289
300	5361	53612	12169	121688	21068	210683	33209	47139	471388	471388	56979	569789	74421	744214	94201	942008	117054	1170538
350	6242	62417	14141	141407	24486	244864	38596	54786	547864	547864	62223	622229	86495	864953	109484	1094836	136044	1360441
400	7104	71043	16123	161226	27918	279183	44006	62465	624650	624650	75504	755044	98618	986180	124828	1248282	155111	1551114
450	7979	79789	18107	181074	31355	313551	49223	70155	701547	701547	84799	847993	110758	1107582	140195	1401950	174206	1742061

Minimum and maximum flow rates to achieve accuracy in (kg/hr).
Pipe ID based on schedule 40 steel.

TABLE 83 - SATURATED STEAM FLOW RATES AT SELECTED PROCESS PRESSURES (English)

Pressure (psig)	100mm		150mm		200mm		250mm		300mm		350mm		400mm		450mm		500mm	
	min	max	min	max	min	max	min	max	min	max	min	max	min	max	min	max	min	max
1	134	1342	305	3045	527	5272	831	8310	1180	11796	1426	14259	1862	18624	2357	23574	2929	29292
2	257	2574	584	5842	1012	10116	1595	15946	2264	22635	2736	27360	3574	35735	4523	45232	5621	56206
4	493	4927	1118	11181	1936	19361	3052	30518	4332	43319	5236	52362	6839	68391	8657	86568	10757	107569
6	722	7218	1638	16380	2836	28364	4471	44708	6346	63461	7671	76709	10019	100191	12682	126819	15759	157586
10	1172	11723	2661	26605	4607	46069	7262	72616	10308	103076	12459	124593	16273	162734	20599	205985	25596	255956
14	1619	16189	3674	36739	6362	63618	10028	100276	14234	142340	17205	172052	22472	224722	28445	284447	35345	353453
18	2065	20649	4686	46861	8115	81146	12791	127905	18156	181558	21946	219458	28664	286639	36282	362821	45084	450841
22	2500	25003	5674	56742	9826	98256	15487	154874	21984	219840	26573	265730	34708	347077	43932	439321	54590	545899
26	2965	29649	6729	67286	11651	116514	18365	183653	26069	260690	31511	315109	41157	411571	52096	520956	64734	647339
28	3198	31979	7257	72574	12567	125670	19809	198086	28118	281178	33987	339873	44392	443916	56190	561898	69821	698213
30	3431	34311	7787	77866	13484	134835	21253	212531	30168	301683	36466	364658	47629	476289	60287	602874	74913	749131

Minimum and Maximum Flow Rates to achieve Accuracy in CFPM (14.7 PSIA and 70 °F).
PipeID Based on Schedule 40 Steel.

TABLE 84 - AIR FLOW RATES AT 60 °F CONDITIONS

Density (lb/ft ³)	Pressure (PSIG)	4"		6"		8"		10"		12"		14"	
		min	max	min	max	min	max	min	max	min	max	min	max
0.076	0	120	1197.9	271	2715	521	5211	821	8214	1166	11659	1409	14093
0.103	5	161	1605.3	364	3638	698	6983	1101	11007	1563	15625	1889	18887
0.128	10	201	2012.8	456	4562	876	8756	1380	13802	1959	19591	2368	23681
0.180	20	283	2827.7	641	6409	1230	12301	1939	19389	2752	27523	3327	33268
0.232	30	364	3642.6	826	8256	1585	15846	2498	24977	3545	35454	4286	42855
0.284	40	446	4457.5	1010	10103	1939	19391	3056	30564	4339	43386	5244	52443
0.336	50	527	5272.4	1195	11950	2294	22936	3615	36152	5132	51317	6203	62030
0.388	60	604	6037.3	1380	13797	2648	26481	4174	41740	5925	59249	7162	71618
0.440	70	690	6902.2	1564	15644	3003	30026	4733	47328	6718	67181	8121	81205
0.493	80	772	7717.1	1749	17490	3357	33571	5292	52915	7511	75113	9079	90792
0.545	90	853	8532.0	1934	19337	3712	37116	5850	58504	8304	83044	10038	100379
0.596	100	935	9346.9	2118	21184	4066	40661	6409	64091	9098	90976	10977	109967
0.649	110	1016	10161.8	2303	23031	4421	44206	6998	69979	9891	98907	11955	119554
0.700	120	1098	10976.7	2488	24878	4775	47751	7527	75266	10684	106839	12914	129142
0.752	130	1179	11791.6	2673	26725	5130	51296	8084	80854	11477	114771	13873	138729
0.804	140	1261	12606.5	2857	28572	5484	54841	8644	86442	12270	122703	14832	148317
0.856	150	1342	13421.4	3042	30419	5839	58386	9203	92030	13063	130634	15790	157904
1.116	200	1749	17495.9	3965	39654	7611	76111	11997	119968	17029	170293	20884	208841
1.636	300	2564	25644.8	5812	58123	11156	111560	17585	175846	24961	249609	30171	301714

Density (lb/ft ³)	Pressure (PSIG)	16"		18"		20"		24"		30"		36"	
		min	max	min	max	min	max	min	max	min	max	min	max
0.076	0	1841	18407	2330	23300	2895	28953	4187	41875	6999	69995	9738	97377
0.103	5	2467	24669	3122	31225	3880	38800	5612	56118	9380	93803	13050	130498
0.128	10	3093	30930	3915	39150	4865	48648	7037	70362	11761	117611	16362	163620
0.180	20	4345	43452	5500	55000	6834	68344	9885	98848	16523	165227	22986	229863
0.232	30	5597	55974	7085	70851	8804	88039	12733	127335	21284	212843	29611	296106
0.284	40	6850	68497	8670	86701	10773	107735	15582	155821	26046	260459	36235	362348
0.336	50	8101	81019	10255	102552	12743	127431	18431	184308	30807	308075	42860	428591
0.388	60	9354	9354	11840	118402	14713	147127	21279	212794	35569	355691	49483	494834
0.440	70	10606	106063	13425	134253	16682	166822	24128	241281	40331	403307	56108	561077
0.493	80	11859	118586	15010	150103	18652	186518	26977	269767	45092	450923	62732	627320
0.545	90	13111	131108	16595	165953	20621	206214	29825	298254	49854	498539	69350	693503
0.596	100	14363	143630	18180	181804	22591	225909	32674	326741	54615	546155	75981	759806
0.649	110	15615	156152	19765	197654	24560	245605	35523	355227	59377	593771	82605	826048
0.700	120	16869	168675	21350	213505	26530	265301	38371	383713	64139	641387	89229	892291
0.752	130	18120	181197	22935	229355	28500	284996	41220	412200	68900	689003	95853	958534
0.804	140	19372	193719	24521	245205	30470	304692	44069	440687	73662	736619	104278	1042777
0.856	150	20624	206242	26106	261056	32439	324387	46917	469173	78423	784235	109102	1091020
1.116	200	26885	268853	34037	340307	44287	442866	61161	611606	102232	1022315	142223	1422234
1.636	300	39408	394076	49881	498812	61982	619823	89647	896471	149847	1498474	208466	2084663

Flanged Insertion Meter

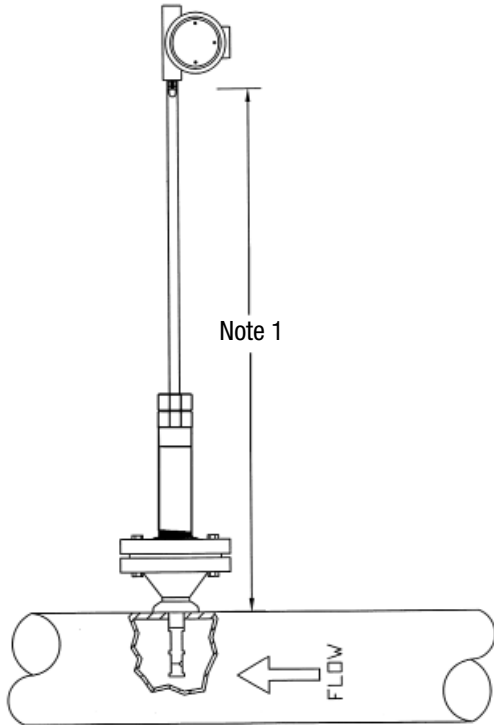

1-1/2" MNPT Insertion Meter

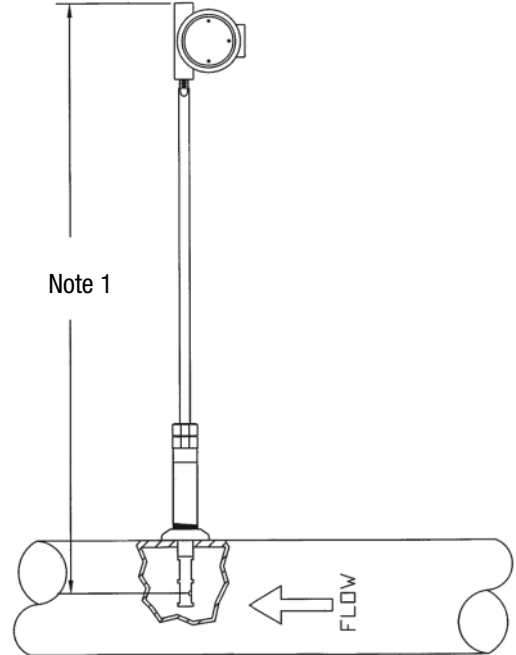

1-1/2" insertion Meter Assembly with Insertion Tool and Ball Valve

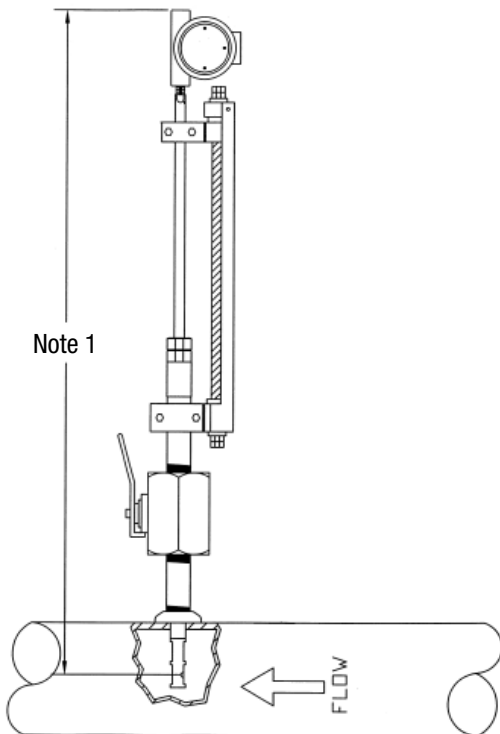

1-1/2" Welded Insertion Meter

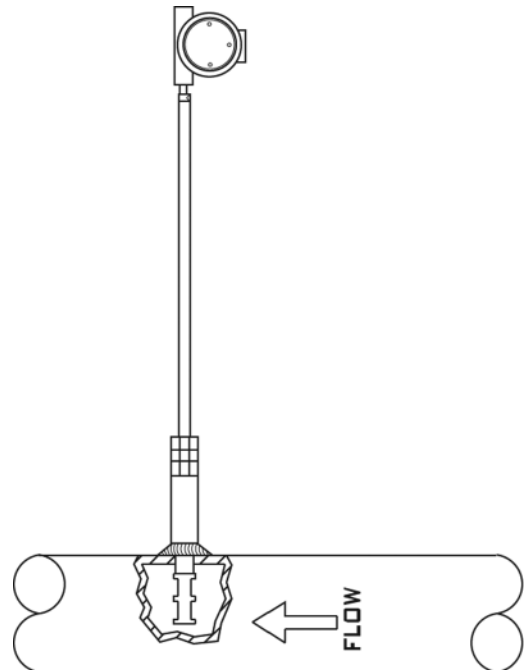

Note 1: Length dependent on pipe diameter, thickness, and mounting.

VX	MODEL
STYLE	
I	Insertion

SIZE: PIPE I.D. / MAX. INSERTION DEPTH *	
12	4"-24" / 12"
24	25"-36" / 18"
36	37"-72" / 24"
48	73"-144" / 36"

FLUID TYPE	
G	Gas
L	Liquid
S	Steam

MAX TEMP.	
4	450 °F

MATERIAL	
6	316 SS

MOUNTING CONNECTION	
C	Insertion with Flange.
D	Insertion. With 1.5 MNPT Thread.
E	Insertion, Welded.
F	Other.

FLANGE RATING†	
A	150# ANSI RF
B	300# ANSI RF
C	600# ANSI RF
D	Other
N	None

DISPLAY	
L2	Local with RS232
R2	Remote with RS232
L4	Local with RS485
R4	Remote with RS425

POWER	
04	24Vdc
12	120Vac
22	220Vac

ACCESSORIES	
MODEL NO.	DESCRIPTION
VTX330600	Insertion Tool Long
VTX330601	Insertion Tool Short
VTX76-F107-01	Ball Valve 1.5 NPT 304 SS
VTX77-107-01	Ball VLV 1.5 NPTF Bronze
VTX83-100-01	Ball VLV 1.5 NPTF Carbon Steel

To allow us to confirm selection please return completed application data sheet found on Aalborg's web site at www.aalborg.com.

1. Style Insertion.
2. Select meter size to match internal pipe diameter (for insertion style select pipe diameter).
3. Confirm minimum and maximum flow ranges to maintain stated accuracy from liquid, steam, or air from Tables 82 to 85 are within your requirements.
4. For other gas applications consult factory.
5. Select fluid type.
6. Select maximum temperature capability.
7. Select desired **Material of Construction.
8. Select mounting connection.
9. Confirm maximum pressure capability of flange/meter rating with process conditions and select flange rating from Table 81.
10. Confirm suitability of standard local mounted electronics.
11. Select desired transmitter power.
12. Provide: Fluid, Fluid Viscosity, Minimum & Maximum Operating Pressure, Minimum & Maximum Operating Temperature, Density/Specific Gravity or Specific Volume.
13. Provide minimum and maximum flow range.

Options: Remote mount electronics up to 100 ft. (30.5 m).

† = Insertion Style for Alignment Ring Selection.

* = Depends on pipe wall thickness and mounting.

** = The selection of materials of construction, is the responsibility of the customer. The company accepts no liability.

VX I — 12 L — 5 6 E N — L2 22

EXAMPLE: VXI-12L-54EB-L222

SPECIFY: FLUID NAME OR MEASURING DENSITY, FLOW RATE, TEMPERATURE AND PRESSURE (STEAM, GASES).

Vortex meter, Insertion style, 10" diameter size, Liquid at maximum 500 °F, 316 stainless steel, Insertion Welded Mounting Connection, Flange 300# ANSI RF, Local display with RS232, 220V power.